



SmartZone 300 Rack Mount Kit Quick Setup Guide

This Rack Mount Kit Quick Setup Guide provides step-by-step instructions on how to install the Ruckus SmartZone 300 (SZ300) into a server rack using the Ruckus Wireless 902-S330-0000 kit. The SZ300 is standard 2U server designed for mounting in a standard EIA 19" server rack.

Before You Begin

Before deploying your Ruckus Wireless product, verify that all items listed in Package Contents below are included in the package. If any item is damaged or missing, notify your authorized Ruckus Wireless sales representative. Also, make sure that you have prepared the required hardware and tools.

NOTE: Some standard EIA 19" server racks have square or slotted mounting holes. The fasteners in this kit may not work with these racks, requiring the customer to supply rack-mount fasteners.

DANGER: Observe careful handling. The kit may contain sharp edges.

NOTE: Using sliding rails could result in non-compliance with Seismic Zone 4 requirements of NEBS-3 certification.

This Guide in Other Languages

请从以下网站获得该指南的简体中文版 <https://support.ruckuswireless.com>.

Vous trouverez la version française de ce guide à l'adresse suivante <https://support.ruckuswireless.com>.

このガイドの日本語版は <https://support.ruckuswireless.com> でご覧ください。

이 가이드의 한국어 버전은 웹 사이트 (<https://support.ruckuswireless.com>) 에서 확인하시기 바랍니다.

Veja a versão em português (Brasil) deste guia em <https://support.ruckuswireless.com>.

Puede ver la versión en español (América Latina) de esta guía en <https://support.ruckuswireless.com>.

What You Will Need

- No. 1 Phillips screwdriver
- Ruler for measuring the rack depth

Package Contents

A complete rack mount installation kit includes two rail assemblies and all of the items listed below:

- Two outer rails with front and rear mounting brackets
- Two inner rails with safety stops
- Eight M4 x 4mm long pan head screws
- Two M5 x 20mm long pan head screws
- This *Rack Mount Kit Quick Setup Guide*

Step 1: Separate the Rail Assemblies into Outer and Inner Rails

1. Extend the inner rail until it locks.
2. Slide the plastic tab towards the direction of the extension lock and pull it in the direction of the arrow (as shown in the following figure) to release the inner rail.
3. Remove the inner rail from the outer rail assembly.

FIGURE 1 Separate the rail assemblies

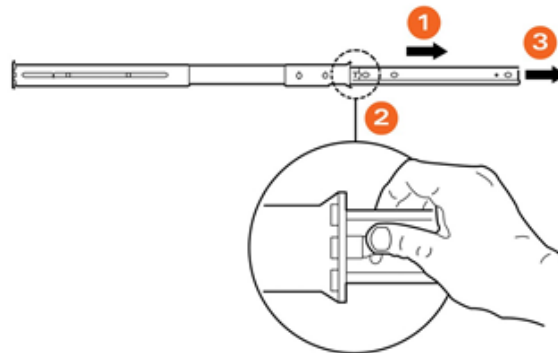

Step 2: Assemble the Outer Rails to the Inside of the Rack

1. Extend the outer rail assemblies with the front stamped portion protrusions positioned into the slots of the rack. Repeat this on the opposite end of the rail until its protrusions are positioned in the back of the rack.
2. Repeat Step 1 on the adjacent side of the rack. Ensure that the correct slot levels on the rack are aligned with the

adjacent side rail assembly as shown in the following figure.

FIGURE 2 Assemble the outer rails

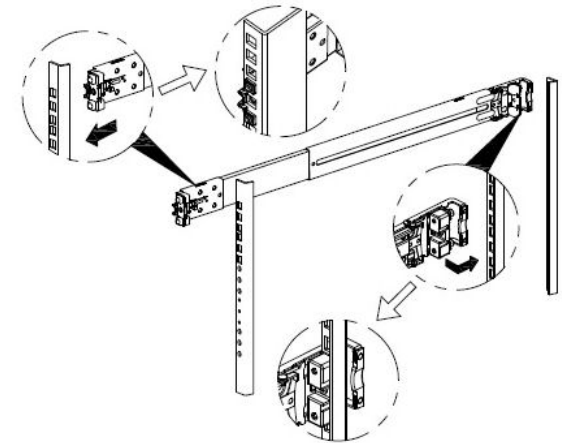

Step 3: Attach the Inner Rails to the Server

1. Attach the inner rail to the side of the server chassis. To do this, align the protrusion on the side of the server to the keyhole cutout on the inner rail, and slide it in until you hear a click.
2. Use one (1) M4 x 4 screw to fasten the inner rail to the server chassis. Fasten until snug.
3. Repeat Steps 1 and 2 above for the other side of the chassis.

FIGURE 3 Attach the inner rails to the server chassis

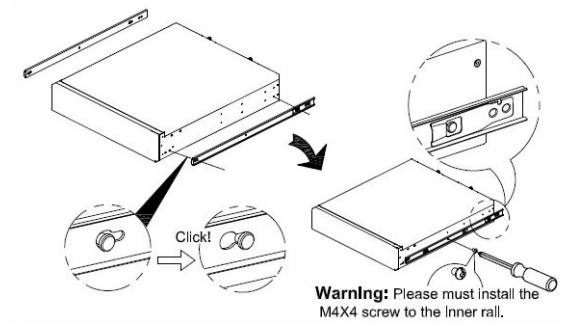

Step 4: Fasten the Front Mounting Brackets and Handles to the Server Chassis

The brackets, handles and mounting hardware can be found in the accessory box in the top tray of the server shipping carton.

1. Using three M4 x6mm long black fasteners, attach one of the two front mounting brackets to the right side of the server chassis.
2. Using two M3 x4mm fasteners, attach one of the two handles to the mounting bracket.
3. Repeat steps 1 and 2 on the left side of the server chassis.

FIGURE 4 Attach the mounting bracket and handle



Step 5: Slide the Inner Rails into the Outer Rails and Secure to the Rack

DANGER: The SZ300 is heavy (45 lbs/20.4 kg). Two people should work together to lift and slide the server into the rack. Ruckus strongly recommends against one person attempting to perform this task alone.

1. On the inner rail, release the lock on both the left and right inner rails (attached to the server). See
2. Extract the ball retainer forward to the front of the rack until the middle member locks into place.

3. Align the inner rails (attached to the server) with the extracted ball retainer of the outer rail assemblies (attached to the rack).
4. Engage the matching rails, and slide the server chassis into the rack until the two spring safety locks snap into place.
5. Engage the matching rails, and then slide the server chassis into the rack until the two spring safety locks snap into place.
6. Pull the plastic tabs on the left and right inner slides and then continue to push the server into the rack until the front tabs of the server are seated against the rack vertical rails. See the following figure.
7. Secure the server to the rack using (1) M5 fastener through the front angle bracket of the server to the threaded portion of rail assemble in the rack. Repeat this step on the other side of the server.

FIGURE 5 Secure the server to the rack

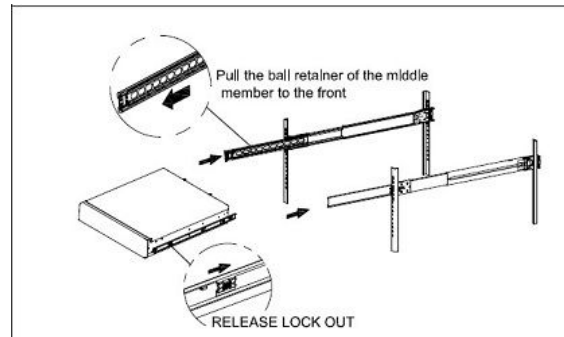

NOTE: Ensure the M5 fasteners are snug against the front brackets on either side of the server to properly secure the server to the rack.

Congratulations! You have completed mounting the SZ300 into the server rack.

Copyright © 2017 Brocade Communications Systems, Inc. All rights reserved. Ruckus, Ruckus Wireless are trademarks of Ruckus Wireless, Inc. All other company and product names mentioned in the documentation are held to be trademarked (and registered) by the primary holders.